

CONF-761012-9

TITLE: PULSED ENERGY STORAGE IN FUSION DEVICES

AUTHOR(S): K. I. Thomassen, J. D. Rogers, F. L. Ribe, D. M. Weldon, C. E. Swanrack, H. F. Vogel, LASL; H. G. Rylander, W. F. Weldon, K. M. Tolik, M. D. Driga, W. L. Bird, Jr., H. H. Woodson, University of Texas at Austin; C. J. Mole, R. E. Stillwagon, Westinghouse Electric Corporation

SUBMITTED TO: Sixth IAEA Conference to be held in Berchtesgaden West Germany, October 6-13, 1976

NOTICE
This report was prepared as an account of work sponsored by the United States Government. Neither the United States nor the United States Energy Research and Development Administration, nor any of their employees, nor any of their contractors, subcontractors, or their employees, makes any warranty, express or implied, or assumes any legal liability or responsibility for the accuracy, completeness or usefulness of any information, apparatus, product, or process disclosed, or represents that its use would not infringe privately owned rights.

By acceptance of this article for publication, the publisher recognizes the Government's (license) rights in any copyright and the Government and its authorized representatives have unrestricted right to reproduce in whole or in part said article under any copyright secured by the publisher.

The Los Alamos Scientific Laboratory requests that the publisher identify this article as work performed under the auspices of the USERDA.

los alamos
scientific laboratory
of the University of California
LOS ALAMOS, NEW MEXICO 87544

An Affirmative Action/Equal Opportunity Employer

MASTER

Pulsed Energy Storage in Fusion Devices

by

K. I. Thomassen, J. D. Rogers, F. L. Ribe
D. M. Weldon, C. E. Swannack, H. F. Vogel
Los Alamos Scientific Laboratory
Los Alamos, New Mexico

H. G. Rylander, W. F. Weldon, K. M. Tolk
M. D. Driga, W. L. Bird, Jr., H. H. Woodson
University of Texas at Austin
Austin, Texas

C. J. Mole, R. E. Stillwagon
Westinghouse Electric Corporation
Pittsburgh, Pennsylvania

Abstract

Research and development on pulsed energy technologies, primarily for pulsed high-beta fusion systems, is described. Systems studies at Los Alamos and elsewhere have served to define these required technologies, which include fast discharging homopolar machines, pulsed superconducting coils, and the associated switching technology. Programs at the Los Alamos Scientific Laboratory, Westinghouse, and The University of Texas are described here.

Introduction

Next generation large fusion devices are of such a size as to require new technologies to meet the requirements for the delivery of pulsed energy. In pulsed high- β devices this dictates the replacement of capacitive systems by pulsed superconducting coils, inertial storage, or other types of moderately fast energy transfer systems. We have examined these requirements for a number of fusion systems and are developing pulsed superconducting coils, fast discharging homopolar machines, and large capacity interrupting switches for these purposes.

This paper gives the results of and describes presently ongoing pulsed energy-storage programs at the Los Alamos Scientific Laboratory (LASL), The University of Texas (UT), and Westinghouse Electric Corporation (WEC). These include systems studies, machine design and construction, superconducting coil fabrication and testing, and vacuum interrupter use in magnetic energy transfer experiments. These programs all address the technology of energy transfer in the 100- μ s to 500-ms time scale, with energies as large as 60 GJ.

The fusion devices requiring large, fast energy delivery systems include toroidal and linear theta pinches, liners, toroidal Z-pinches, glass lasers, and tokamaks. In the pinches and liners, magnetic fields for plasma compression are driven by these large energy systems, while tokamaks and toroidal Z-pinches require pulsed supplies for ohmic heating. The flash lamp supplies for glass lasers require ~ 100 MJ on the 0.1 to 0.5ms time scale.

A toroidal theta-pinch reactor (the RTPR) requires ~ 60 GJ delivered in 30 ms, the linear theta-pinch fusion/fission hybrid reactor needs ~ 25 GJ in 2 ms, and a liner reactor may require ~ 10 GJ on a 1 ms timescale. The ohmic heating coils in present US designs of tokamak EPR's (Experimental Power Reactors) have ~ 1 to 2 GJ of stored energy, and the storage currents must be reversed in 0.5 to 2 s to induce plasma current. Tokamak reactor systems require even larger ohmic heating systems. Similar systems are needed for toroidal Z-pinches to ignite the plasma by ohmic heating.

Toroidal Theta-Pinch Energy Supplies

The LASL Reference Theta Pinch Reactor (RTPR)¹ design has defined requirements on the power supplies to drive the compression coils. A total of 63 GJ must be delivered in 30 ms, held for 70 ms, and returned to storage in 30 ms. A cycle transfer efficiency of 95% is required.

To meet these requirements, WEC advanced the design of a 1.3 GJ homopolar machine (50 of these will be required).² Further study under EPRI (Electric Power Research Institute) auspices by LASL, UT, and WEC, has resulted in a complete conceptual engineering design of this machine. There are eight drum-rotors in the machine which develops 11 kV at 12.25 MA while discharging in 30 ms. A scaled 10 MJ model of this machine is now in final engineering design, with plans to construct it in the next few years. The model machine is a test of high surface speed (277 m/s) operation of solid copper-graphite brushes at high currents (1550 A/cm²), the superconducting field coils, and operation with high deceleration (30-ms stopping time). The machine will produce 1.55 MA at 719 V.

The model machine, shown schematically in Fig. 1, has two rotors spinning oppositely. Current flows axially along the rotor surface for the length of the machine, with brushes on the inner surface at each end of each rotor. Return current flows on an outer coaxial sleeve to minimize internal inductance. Superconducting NbTi coils, storing ~ 8 MJ of energy, provide an average of 2.2 T radial field at the rotor surface. A conceptual design of the machine including electrical, mechanical, and thermal considerations has been completed.

DISCHARGE TIME
30 ms

10 MJ
SCALE
MODEL

ROTOR DIA 72 cm
VOLTAGE 775 V
CURRENT 1.4 MA

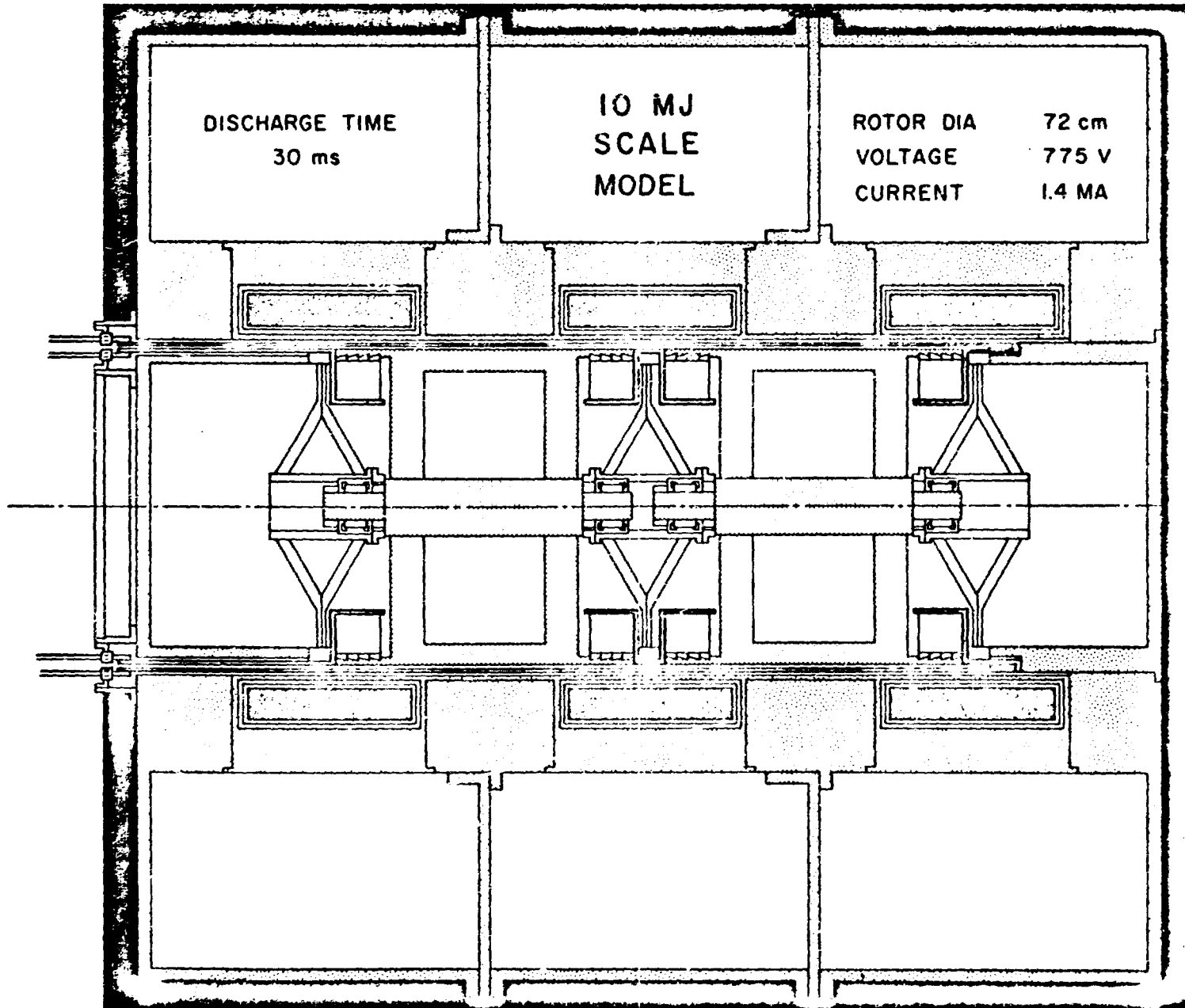

Tokamak Ohmic Heating

Joint systems studies by LASL, UT, and WEC into homopolar machines and pulsed superconducting coils for tokamak EPR's are underway. As in the high- β systems where the machine load is inductive, the capacitive nature of the homopolar machine is ideal for resonating the energy out of and back into the ohmic heating coils. The simple circuit of Fig. 2 provides the necessary energization of the plasma, and was used to determine the necessary startup energy, transfer times, and OH coil requirements. The OH coil system, its transformer coupling to the plasma, and the plasma inductance and variable resistance are represented. A zero dimension code describes plasma current buildup, and incorporates resistive heating, bremsstrahlung, line radiation, charge exchange, plasma transport, etc. The power supply ($\pm V$) charges the OH coil with R and C_h bypassed. On turning off this supply, R and C_h are switched in, giving an initial fast rising current. On crowbaring R the homopolar capacitor completes the energy transfer on the several second time scale and is bypassed during the burn. The circuit is sufficient for establishing the initial rate of change of current (10 to 50 MA/s), stored energy (1 to 2 GJ), the coil primary circuit parameters (peak voltages \sim 30 to 60 kV, peak currents \sim 150 to 300 kA, and volt-seconds \sim 100 to 200) for typical tokamak EPR's. Homopolar machine designs are being carried out by WEC, and superconducting OH coil problems are being assessed at LASL.

Homopolar Machine Development

Many of the applications described in this paper require very fast transfer times (as small as 0.1 ms). The limitations to extremely fast discharge times for homopolar machines have been studied by UT,³ and a 1-ms model machine is being constructed. Figure 3 shows the two counter-rotating aluminum rotors which will discharge 10^6 A in 3 ms from a speed of 28,000 rpm into a $30\text{-}\mu\Omega$, $1/4\text{-}\mu\text{H}$ load at 80% efficiency, or at half speed in 1 ms into a short circuit. The machine capacity is 16.6 F (360 kJ stored) and has a 25-nH , $15\text{-}\mu\Omega$ internal impedance.

The pulsed exciting coil stores 1.2 MJ and has an average magnetic field of 4 T between brushes. The rotors are supported on oil lubricated hydrostatic journal bearings and are driven by two gas turbines.

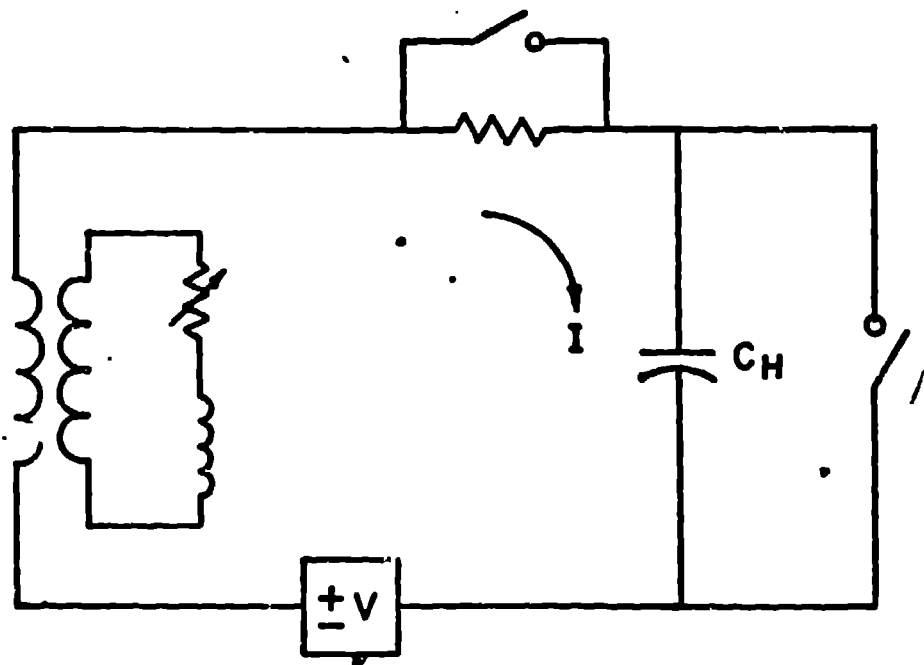

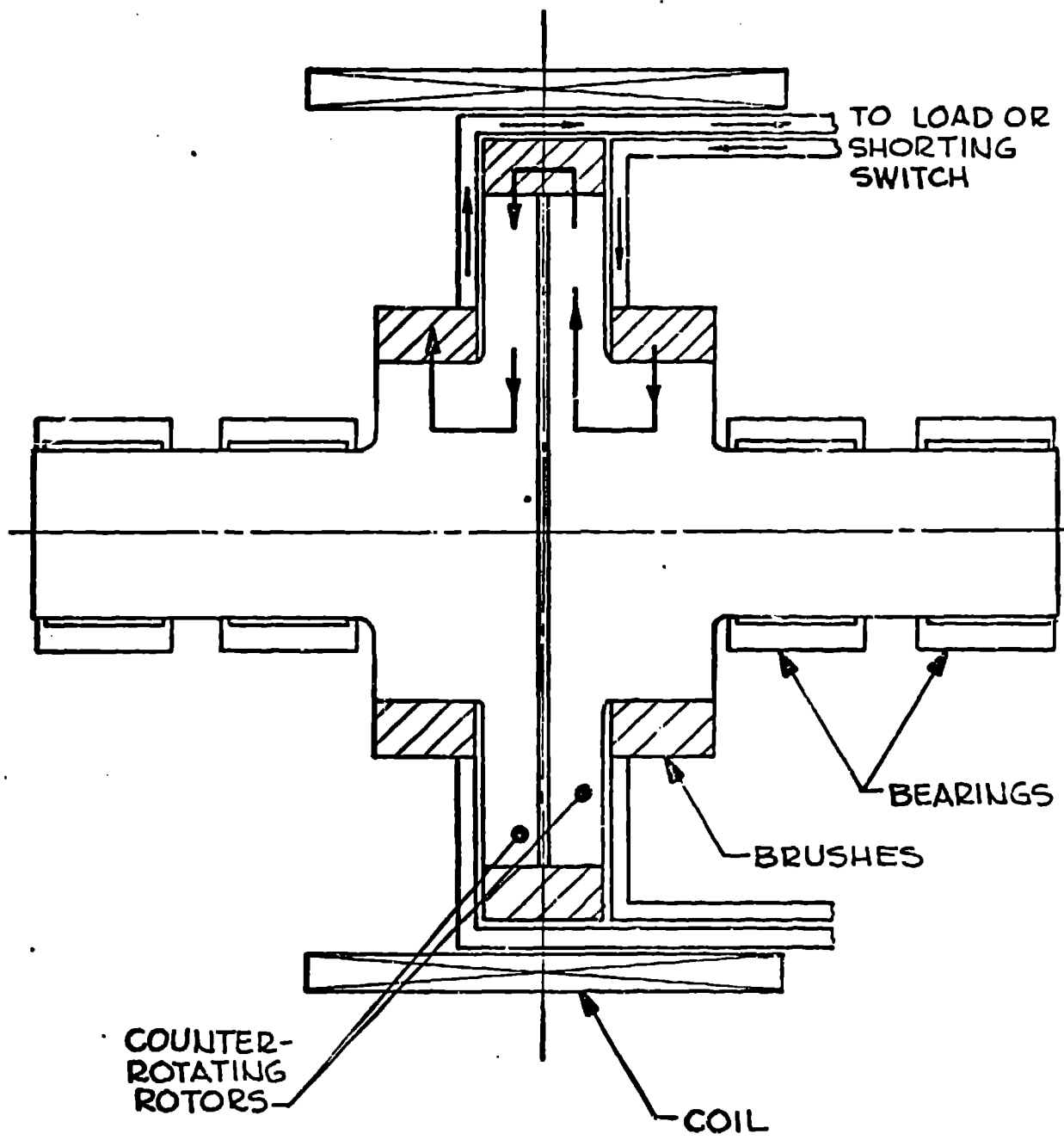

Fig. 3 Fast Discharging Homopolar Machine

Concurrent with the machine construction programs (the 1-ms and 30-ms machines), a brush testing program is in progress at UT. Data taken in air on a steel rotor with surface speeds up to 220 m/s, and with long current pulses applied to the brush have been described by Ortloff⁴ and Casstevens.⁵ More recently, a high speed (450-m/s surface speed) aluminum rotor with various surface treatments is being used in a controlled atmosphere facility. The gas composition, humidity, and temperature are controlled, and sliding velocity, current, voltage drop, friction force, normal force, and brush and rotor temperatures are monitored. A 60-ms pulse giving current densities of 1550 A/cm² can be applied.

Magnetic Energy Transfer and Storage (METS)

The METS program at LASL, begun several years ago, is leading to the development of 400-kJ, 0.7-ms transfer, superconducting coils.⁶ The appropriate cryogenic and switching technology is also being developed. These coils are part of a 500-MJ system to drive the Scyllac Fusion Test Reactor (SFTR). Three 300-kJ coils have been constructed and are being tested to determine the ac losses during discharge. The coils are designed for less than 0.3% energy loss during this rapid transfer, and to remain superconducting even during the rapid (0.7 ms) discharge. An earlier 300-kJ coil with a 2700 filament monolithic conduction (6:1, Cu:NbTi) was successfully built and tested by LASL. By design it did not remain superconducting during transfer and had 2-3% losses. Peak current and voltage were 10 kA and 45 kV.

The three 10-kA coils in the present program were constructed by MCA (Magnetics Corporation of America), WEC and IGC (Intermagnetics General Corporation). The IGC coil, shown in Fig. 4, has a single layer edge wound cable of 319 multi-strand, 0.39 mm dia CuNi-Cu matrix NbTi multifilament wires. It is vacuum impregnated with epoxy resin. In tests to date, a normal transition occurred at ~ 3 kA so the coil has been disassembled to redesign the supports for the terminals. Motion of the lead-in conductor may be the problem.

The MCA coil uses a single layer, edge wound multistrand braid with 1224 monofilament wires. Each wire is 0.127-mm dia, having 1.58:1 Cu:NbTi. The coil has an open structure, with the braid bonded to a "staircase" helical support structure with epoxy resin. Operation of the coil was limited to 4.8 kA by heating damage to the structure from a low current quench while operating without a quench detector circuit. Losses during transfer were found to be less than 0.3%.

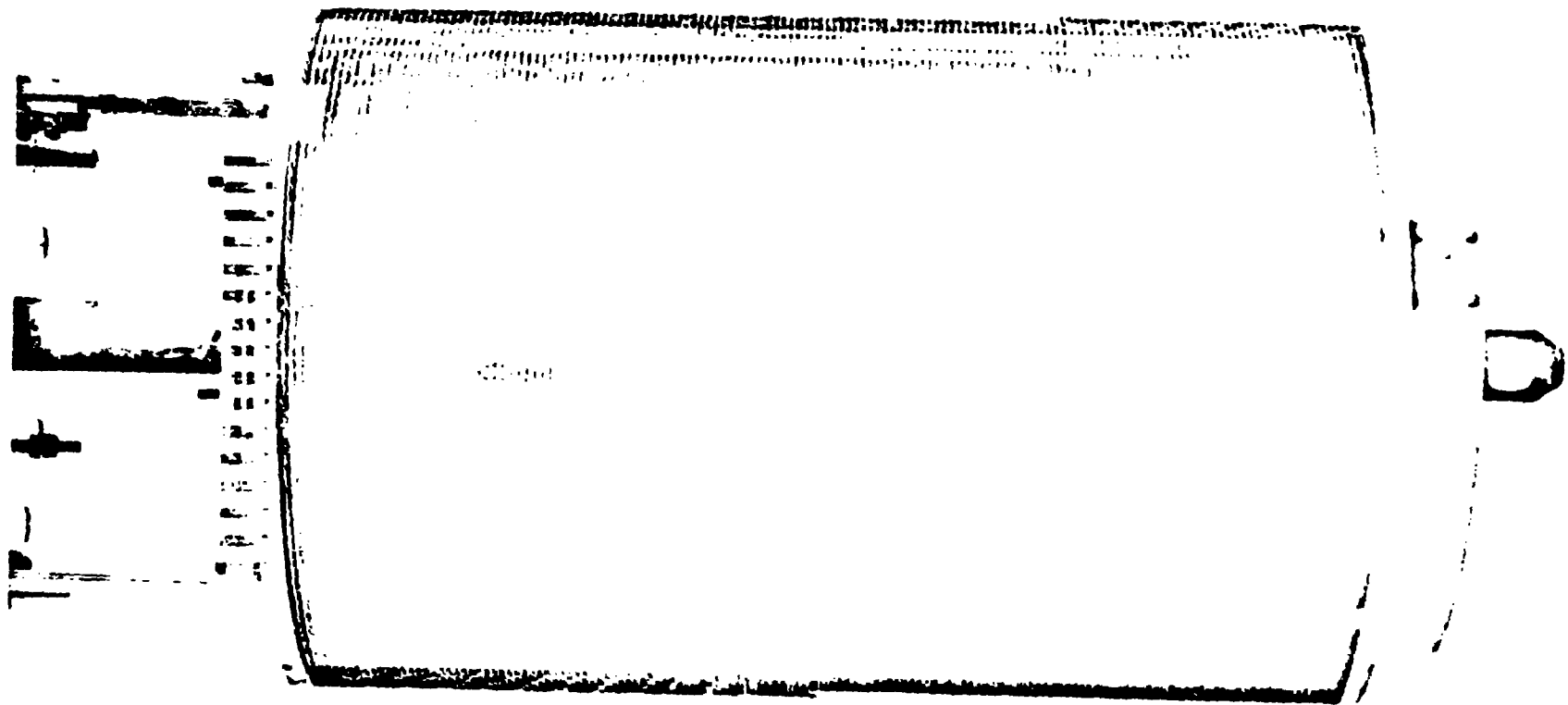

Westinghouse is constructing a coil with a 4-layer winding using 72 strands of 0.51-mm dia Cu matrix NbTi multifilament wires in twelve bundles to form a cable wrapped around an insulated strap. The structure is open to allow He cooling. The coil will be delivered in August 1976 for testing. Its design calls for 2% losses. Difficulties in fabricating the CuNi-Cu matrix wire for the first design led to the higher loss, less complicated cable now used.

Switching

The major requirements for fast transfer of energy from inductive systems are high current interruption and high voltage hold off. Dc switching studies using vacuum interrupters developed for ac power systems are in progress at LASL and UT. At LASL, the emphasis is on achieving the highest possible power ratings. To date we have interrupted 28 kA and withstood 66 kV using a conventional 7-inch Westinghouse interrupter. Saturable reactors are used in series with the interrupter to limit di/dt at current zero and improve reliability. Reactors with ferrite cores, 20-mil silicon iron laminations, 10-mil Permalloy, or special 4-mil silicon iron have been used. Flux ratings ranging from 0 to 0.2 webers are used, with reliability improving at the higher ratings.

At UT, the emphasis is on exploring the pertinent parameters governing interruption (rate of change of current prior to interruption, rate of increase of voltage after interruption, deionization time, conduction time, etc). For example with a Westinghouse WL23318 bottle, data gathered at 3.2-kA current and 30-kV peak forward voltage they find a relationship between the fall of commutated current $F = di/dt$ the rise of forward voltage $R = dv/dt$ and the deionization time τ . The relationship is $RF = 1.45 \tau^{-6} = 2 \times 10^{-4}$ where $600 < R < 2000$ v/ μ s and $3 < F < 80$ A/ μ s. Please call for improving the facility to gather data at 10 to 20-kA interrupting currents.

References

1. F. L. Ribe, R. A. Krakowski, K. I. Thomassen, and T. A. Coultas, Nuclear Fusion Special Supplement 1974 Fusion Reactor Design Problems, (IAEA Vienna, 1974), p 99.
2. G. Rostagni, in Pulsed Fusion Reactors, Eric-Trapani (Sicily), September 9-20, 1974 (Pergamon Press, Oxford, New York, 1975) p 594.
3. M. D. Driga, S. A. Nasser, H. G. Rylander, W. F. Weldon, and H. H. Woodson, IEEE Transactions on Plasma Science Vol. PS-3, No. 4, p 209 (1975).
4. D. J. Ortloff, "The Design of a Brush Test Machine," Masters' Thesis in Mechanical Engineering, The University of Texas at Austin, January 1975.
5. J. M. Casstevens, "Measurements of the Friction and Wear Characteristics of Copper-Graphite Sliding Electrical Contact Materials at Very High Speeds and Current Densities," Masters' Thesis at the University of Texas at Austin, August 1976.
6. C. W. Swannack, R. A. Haarman, Jr., D. G. Lindsay and D. M. Weldon, Proceedings of the Sixth Symposium on Problems of Fusion Research, November 18-21, 1975, San Diego. IEEE, New Brunswick, New Jersey, 75 CH 1097-5 NPS, p 662 (1976)